

# EQUAL ANGLES

**HOT ROLLED**, dimensional tolerances and grades according to ASTM A276, ASTM A484, ASTM A479, ASME SA479, MTC EN 10204 3.1

**LASER FUSED**, according to ASTM A1069, dimensional tolerances and grades, according to ASTM A276, ASTM A484, ASTM A479, ASME SA479, MTC EN 10204 3.1

Standard stainless steel grades 304/L and 316/L  
Annealed and pickled, lengths of 6000 -0/+100 mm

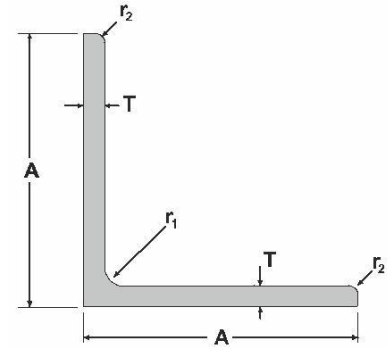

Designation	Dimensions (in mm)			Radius (in mm)		Mass
	A	A	T	r <sub>1</sub>	r <sub>2</sub>	kg/m
15x15x2	15	15	2	2.5	2	0.45
15x15x3	15	15	3	2.5	2	0.65
20x20x2	20	20	2	2.5	2	0.61
20x20x3	20	20	3	3.5	2	0.89
25x25x3	25	25	3	3.5	2	1.13
25x25x4	25	25	4	3.5	2	1.47
25x25x5	25	25	5	3.5	2	1.80
30x30x3	30	30	3	5	2.5	1.37
30x30x4	30	30	4	5	2.5	1.79
30x30x5	30	30	5	5	2.5	2.20
35x35x4	35	35	4	5	2.5	2.11
40x40x3	40	40	3	5	2.5	1.85
40x40x4	40	40	4	6	3	2.43
40x40x5	40	40	5	6	3	3.00
40x40x6	40	40	6	6	3	3.55
45x45x4	45	45	4	6	3.5	2.75
45x45x5	45	45	5	6	3.5	3.40
50x50x3	50	50	3	7	3.5	2.33
50x50x4	50	50	4	7	3.5	3.07
50x50x5	50	50	5	7	3.5	3.80
50x50x6	50	50	6	7	3.5	4.51
60x60x6	60	60	6	8	4	5.47
65x65x6	65	65	6	9	4.5	5.95
65x65x8	65	65	8	9	4.5	7.81

## HOTO STAINLESS STEEL INDUSTRIES SDN BHD

Lot 3, Solok Sultan Hishamuddin 8,  
Kawasan Perusahaan Selat Kelang Utara,  
42000 Pelabuhan Kelang,  
Selangor, Malaysia.

Tel : +60 3176 1764

Fax: +60 3176 4735

[www.hoto.com](http://www.hoto.com)

Company Reg. 285737 -T

# EQUAL ANGLES

**HOT ROLLED**, dimensional tolerances and grades according to ASTM A276, ASTM A484, ASTM A479, ASME SA479, MTC EN 10204 3.1

**LASER FUSED**, according to ASTM A1069, dimensional tolerances and grades, according to ASTM A276, ASTM A484, ASTM A479, ASME SA479, MTC EN 10204 3.1

Standard stainless steel grades 304/L and 316/L  
Annealed and pickled, lengths of 6000 -0/+100 mm

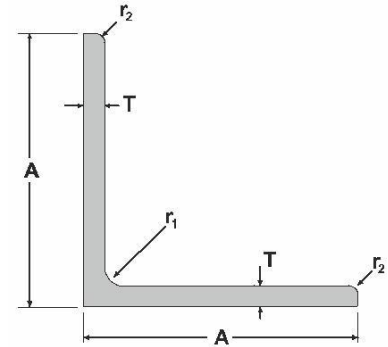

Designation	Dimensions (in mm)			Radius (in mm)		Mass
	A	A	T	r <sub>1</sub>	r <sub>2</sub>	kg/m
65x65x9	65	65	9	9	4.5	8.71
75x75x6	75	75	6	9	4.5	6.91
75x75x8	75	75	8	9	4.5	9.09
75x75x9	75	75	9	9	4.5	10.2
75x75x10	75	75	10	9	4.5	11.2
80x80x6	80	80	6	10	5	7.39
80x80x8	80	80	8	10	5	9.73
90x90x9	90	90	9	10	5	12.3
100x100x6	100	100	6	12	6	9.31
100x100x8	100	100	8	12	6	12.3
100x100x9	100	100	9	12	6	13.8
100x100x10	100	100	10	12	6	15.2
120x120x8*	120	120	8	2	1	14.8
120x120x10	120	120	10	12	6	18.4
120x120x12*	120	120	12	2	1	21.9
120x120x15*	120	120	15	2	1	27.0
125x125x8*	125	125	8	2	1	15.5
125x125x9	125	125	9	12	6	17.4
125x125x10	125	125	10	12	6	19.2
125x125x12	125	125	12	12	6	22.8
125x125x15*	125	125	15	2	1	28.2
130x130x8*	130	130	8	2	1	16.1
130x130x9*	130	130	9	2	1	18.1

## HOTO STAINLESS STEEL INDUSTRIES SDN BHD

Lot 3, Solok Sultan Hishamuddin 8,  
Kawasan Perusahaan Selat Kelang Utara,  
42000 Pelabuhan Kelang,  
Selangor, Malaysia.

Tel : +60 3176 1764

Fax: +60 3176 4735

[www.hoto.com](http://www.hoto.com)

Company Reg. 285737 -T

# EQUAL ANGLES

**HOT ROLLED**, dimensional tolerances and grades according to ASTM A276, ASTM A484, ASTM A479, ASME SA479, MTC EN 10204 3.1

**LASER FUSED**, according to ASTM A1069, dimensional tolerances and grades, according to ASTM A276, ASTM A484, ASTM A479, ASME SA479, MTC EN 10204 3.1

Standard stainless steel grades 304/L and 316/L  
Annealed and pickled, lengths of 6000 -0/+100 mm

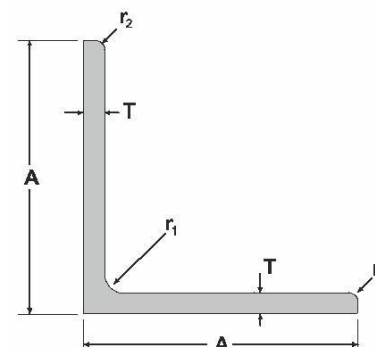

Designation	Dimensions (in mm)			Radius (in mm)		Mass
	A	A	T	r <sub>1</sub>	r <sub>2</sub>	kg/m
130x130x10*	130	130	10	2	1	20.0
130x130x12*	130	130	12	2	1	23.8
130x130x15*	130	130	15	2	1	29.4
150x150x8*	150	150	8	2	1	18.7
150x150x9	150	150	9	12	6	21.0
150x150x10	150	150	10	12	6	23.2
150x150x12	150	150	12	12	6	27.6
150x150x15*	150	150	15	2	1	34.2
175x175x12*	175	175	12	2	1	32.4
175x175x15*	175	175	15	2	1	40.2
200x200x12*	200	200	12	2	1	37.2
200x200x13*	200	200	13	2	1	40.2
200x200x15*	200	200	15	2	1	46.2

Notes :\* Profiles are Laser fused with full penetration, equivalent to hot rolled  
r<sub>1</sub> = laser welded seam with radius <2 mm, radius r<sub>2</sub> is an approximate value Other sizes can be hot rolled upon request with min. of 25 tons  
Other stainless steel grades are produced upon request

## HOTO STAINLESS STEEL INDUSTRIES SDN BHD

Lot 3, Solok Sultan Hishamuddin 8,  
Kawasan Perusahaan Selat Kelang Utara,  
42000 Pelabuhan Kelang,  
Selangor, Malaysia.

Tel : +60 3176 1764

Fax: +60 3176 4735

[www.hoto.com](http://www.hoto.com)

Company Reg. 285737 -T

# UNEQUAL ANGLES

**HOT ROLLED**, dimensional tolerances and grades according to ASTM A276, ASTM A484, ASTM A479, ASME SA479, MTC EN 10204 3.1

**LASER FUSED**, according to ASTM A1069, dimensional tolerances and grades, according to ASTM A276, ASTM A484, ASTM A479, ASME SA479, MTC EN 10204 3.1

Standard stainless steel grades 304/L and 316/L  
Annealed and pickled, lengths of 6000 -0/+100 mm

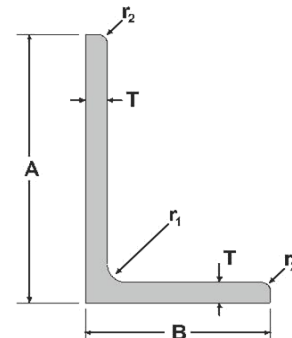

Designation	Dimensions (in mm)			Radius (in mm)		Mass kg/m
	A	B	T	r <sub>1</sub>	r <sub>2</sub>	
45x25x4	45	25	4	5	3.5	1.95
45x30x4	45	30	4	5	3.5	2.27
50x30x5	50	30	5	6	3.5	3.00
50x30x6	50	30	6	6	3.5	3.55
50x40x5	50	40	5	6	3.5	3.40
60x40x5	60	40	5	6	3.5	3.80
65x50x5	65	50	5	9	4.5	4.40
65x50x6	65	50	6	9	4.5	5.23
75x50x6	75	50	6	9	4.5	5.71
75x50x8	75	50	8	9	4.5	7.49
75x50x9	75	50	9	9	4.5	8.35
75x65x6	75	65	6	9	4.5	6.43
90x65x6	90	65	6	10	5.0	7.15
90x65x8	90	65	8	10	5.0	9.41
90x75x9	90	75	9	10	5.0	11.2
100x50x6	100	50	6	10	5.0	6.91
100x50x8	100	50	8	10	5.0	9.09
100x50x10	100	50	10	10	5.0	11.2
100x65x6	100	65	6	10	5.0	7.63
100x65x7	100	65	7	10	5.0	8.85
100x65x8	100	65	8	10	5.0	10.0
100x65x9	100	65	9	10	5.0	11.2
100x65x10	100	65	10	10	5.0	12.4
100x75x6	100	75	6	10	5.0	8.11

## HOTO STAINLESS STEEL INDUSTRIES SDN BHD

Lot 3, Solok Sultan Hishamuddin 8,  
Kawasan Perusahaan Selat Kelang Utara,  
42000 Pelabuhan Kelang,  
Selangor, Malaysia.

Tel : +60 3176 1764

Fax: +60 3176 4735

[www.hoto.com](http://www.hoto.com)

Company Reg. 285737 -T

# UNEQUAL ANGLES

**HOT ROLLED**, dimensional tolerances and grades according to ASTM A276, ASTM A484, ASTM A479, ASME SA479, MTC EN 10204 3.1

**LASER FUSED**, according to ASTM A1069, dimensional tolerances and grades, according to ASTM A276, ASTM A484, ASTM A479, ASME SA479, MTC EN 10204 3.1

Standard stainless steel grades 304/L and 316/L  
 Annealed and pickled, lengths of 6000 -0/+100 mm

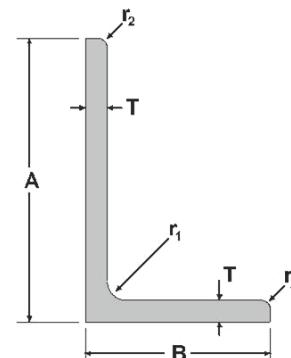

Designation	Dimensions (in mm)			Radius (in mm)		Mass kg/m
	A	B	T	r <sub>1</sub>	r <sub>2</sub>	
100x75x8	100	75	8	10	5.0	10.7
100x75x9	100	75	9	10	5.0	12.0
100x75x10	100	75	10	10	5.0	13.2
125x75x6	125	75	6	11	5.5	9.31
125x75x7*	125	75	7	2	1	10.8
125x75x8*	125	75	8	2	1	12.3
125x75x9	125	75	9	12	6	13.8
125x75x10*	125	75	10	2	1	15.2
125x75x12*	125	75	12	2	1	18.0
125x100x10*	125	100	10	2	1	17.2
130x100x11*	130	100	10	2	1	17.6
150x75x8*	150	75	8	2	1	13.9
150x75x9	150	75	9	2	1	15.6
150x75x10	150	75	10	12	6	17.2
150x75x12*	150	75	12	2	1	20.4
150x75x15*	150	75	15	2	1	25.2
150x90x8*	150	90	8	2	1	14.8
150x90x9	150	90	9	12	6	16.6
150x90x10	150	90	10	12	6	18.4
150x90x12	150	90	12	12	6	21.9
150x90x15*	150	90	15	2	1	27.0
150x100x8*	150	100	8	2	1	15.5
150x100x9*	150	100	9	2	1	17.4
150x100x10	150	100	10	12	6	19.2

## HOTO STAINLESS STEEL INDUSTRIES SDN BHD

Lot 3, Solok Sultan Hishamuddin 8,  
 Kawasan Perusahaan Selat Kelang Utara,  
 42000 Pelabuhan Kelang,  
 Selangor, Malaysia.

Tel : +60 3176 1764

Fax: +60 3176 4735

[www.hoto.com](http://www.hoto.com)

Company Reg. 285737 -T

# UNEQUAL ANGLES

**HOT ROLLED**, dimensional tolerances and grades according to ASTM A276, ASTM A484, ASTM A479, ASME SA479, MTC EN 10204 3.1

**LASER FUSED**, according to ASTM A1069, dimensional tolerances and grades, according to ASTM A276, ASTM A484, ASTM A479, ASME SA479, MTC EN 10204 3.1

Standard stainless steel grades 304/L and 316/L  
Annealed and pickled, lengths of 6000 -0/+100 mm

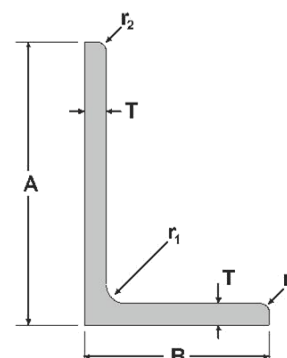

Designation	Dimensions (in mm)			Radius (in mm)		Mass kg/m
	A	B	T	r <sub>1</sub>	r <sub>2</sub>	
150x100x12	150	100	12	12	6	22.8
150x100x15*	150	100	15	2	1	28.2
200x100x10*	200	100	10	2	1	23.2
200x100x12*	200	100	12	2	1	27.6
200x100x15*	200	100	15	2	1	34.2
200x150x12*	200	150	12	2	1	32.4
200x150x15*	200	150	15	2	1	40.2

Notes :\* Profiles are Laser fused with full penetration, equivalent to hot rolled  
r<sub>1</sub> = laser welded seam with radius <2 mm, radius r<sub>2</sub> is an approximate value Other sizes can be hot rolled upon request with min. of 25 tons  
Other stainless steel grades are produced upon request

# CHANNELS – standard size

**HOT ROLLED**, dimensional tolerances and grades according to ASTM A276, ASTM A484, ASTM A479, ASME SA479, MTC EN 10204 3.1

**LASER FUSED**, according to ASTM A1069, dimensional tolerances and grades, according to ASTM A276, ASTM A484, ASTM A479, ASME SA479, MTC EN 10204 3.1

Standard stainless steel grades 304/L and 316/L  
Annealed and pickled, lengths of 6000 -0/+100 mm

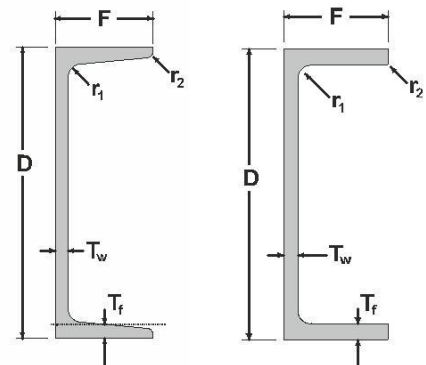

Designation	Dimensions (in mm)				Radius (in mm)		Mass kg/m
	D	F	Tw	Tf	r <sub>1</sub>	r <sub>2</sub>	
50x25x5x6	50	25	5.0	6.0	6	3	3.82
75x40x5x7 <sup>+</sup>	75	100	6.0	8.0	7	3.5	6.70
100x50x5x7.5 <sup>+</sup>	100	50	5.0	7.5	7.5	3.75	9.10
125x65x6x8 <sup>+</sup>	125	65	6.0	8.0	8	4	13.3
150x75x6.5x10 <sup>+</sup>	150	75	6.5	10.0	10	5	18.2
150x75x9x12.5 <sup>+</sup>	150	75	9.0	12.5	2	1	23.3
180x75x7x10.5 <sup>+</sup>	180	75	7.0	10.5	2	1	20.9
200x80x7.5x11 <sup>+</sup>	200	80	7.5	11.0	2	1	24.1
200x90x8x13.5 <sup>+</sup>	200	90	8.0	13.5	2	1	29.3
230x80x8x12 <sup>*</sup>	230	80	8.0	12.0	2	1	27.8
250x90x9x13 <sup>*</sup>	250	90	9.0	13.0	2	1	34.0
250x90x11x14.5 <sup>*</sup>	250	90	11.0	14.5	2	1	39.5
300x90x9x12 <sup>*</sup>	300	90	9.0	12.0	2	1	36.6
300x90x10x15.5 <sup>*</sup>	300	90	10.0	15.5	2	1	42.5
300x90x12x16 <sup>*</sup>	300	90	12.0	16.0	2	1	47.7
380x100x10.5x16 <sup>*</sup>	380	100	10.5	16.0	2	1	53.4
380x100x13x16.5 <sup>*</sup>	380	100	13.0	16.5	2	1	61.6
380x100x13x20 <sup>*</sup>	380	100	13.0	20.0	2	1	65.1

Notes : \*Profiles are Laser fused with full penetration, equivalent to hot rolled

Laser fused channels have non tapered flanges, r<sub>1</sub> = laser welded seam with radius <2

mm <sup>+</sup> Profiles can be hot rolled with a min. quantity of 25 tons

Flange thickness is measured at the centre of the flange

Other stainless steel grades are produced upon request

## HOTO STAINLESS STEEL INDUSTRIES SDN BHD

Lot 3, Solok Sultan Hishamuddin 8,  
Kawasan Perusahaan Selat Kelang Utara,  
42000 Pelabuhan Kelang,  
Selangor, Malaysia.

Tel : +60 3176 1764

Fax: +60 3176 4735

www.hoto.com

Company Reg. 285737 -T

# MISCELLANEOUS CHANNELS

**HOT ROLLED**, dimensional tolerances and grades according to ASTM A276, ASTM A484, ASTM A479, ASME SA479, MTC EN 10204 3.1

**LASER FUSED**, according to ASTM A1069, dimensional tolerances and grades, according to ASTM A276, ASTM A484, ASTM A479, ASME SA479, MTC EN 10204 3.1

Standard stainless steel grades 304/L and 316/L  
Annealed and pickled, lengths of 6000 -0/+100 mm

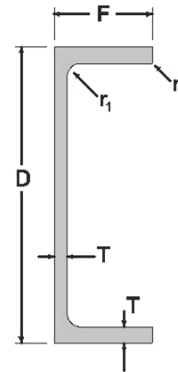

Designation	Dimensions (in mm)			Radius (in mm)		Mass kg/m
	D	F	T	r <sub>1</sub>	r <sub>2</sub>	
40x20x3	40	20	3	3	3	1.78
50x25x3	50	25	3	3	3	2.26
60x30x5	60	30	5	5	3	4.40
60x30x6	60	30	6	6	3	5.18
80x40x4*	80	40	4	2	1	4.86
80x40x5	80	40	5	6	3	6.00
80x40x6	80	40	6	6	3	7.10
100x50x4	100	50	4	6	3	6.14
100x50x5	100	50	5	6	3	7.60
100x50x6	100	50	6	6	3	9.02
120x60x6	120	60	6	6	3	10.9
130x65x6	130	65	6	6	3	11.9
150x75x6	150	75	6	2	1	13.8
150x75x9 <sup>+</sup>	150	75	9	2	1	20.3
200x100x6*	200	100	6	2	1	18.6
200x100x9*	200	100	9	2	1	27.5
200x100x10*	200	100	10	2	1	30.4

Notes : \*Profiles are Laser fused with full penetration, equivalent to hot rolled, r<sub>1</sub> = laser welded seam with radius <2 mm  
<sup>+</sup> Profiles can be hot rolled with a min. quantity of 25 tons  
 Other stainless steel grades are produced upon request

## HOTO STAINLESS STEEL INDUSTRIES SDN BHD

Lot 3, Solok Sultan Hishamuddin 8,  
Kawasan Perusahaan Selat Kelang Utara,  
42000 Pelabuhan Kelang,  
Selangor, Malaysia.

Tel : +60 3176 1764

Fax: +60 3176 4735

[www.hoto.com](http://www.hoto.com)

Company Reg. 285737 -T



# STRUCTURAL Tees

**LASER FUSED**, according to ASTM A1069,  
dimensional tolerances and grades, according to  
ASTM A276, ASTM A484, ASTM A479, ASME  
SA479, MTC EN 10204 3.1

Standard stainless steel grades 304/L and 316/L  
Annealed and pickled, lengths of 6000 -0/+100 mm

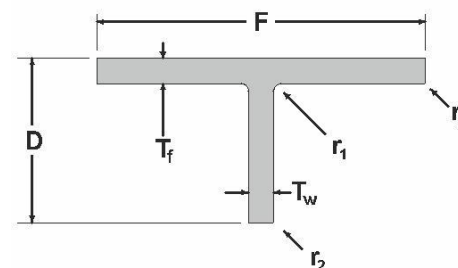

Designation	Dimensions (in mm)				Radius (in mm)		Mass kg/m
	D	F	T <sub>w</sub>	T <sub>f</sub>	r <sub>1</sub>	r <sub>2</sub>	
50x75	50	75	6	6	2	1	5.71
50x100	50	100	6	8	2	1	8.42
62.5x125	62.5	125	6.5	9	2	1	11.8
75x75	75	75	5	7	2	1	6.92
75x100	75	100	6	9	2	1	10.4
75x150	75	150	7	10	2	1	15.6
87.5x90	87.5	90	5	8	2	1	8.94
87.5x175	87.5	175	7.5	11	2	1	20.0
100x100	100	100	5.5	8	2	1	10.4
100x150	100	150	6	9	2	1	15.2
100x200	100	200	8	12	2	1	24.8
125x125	125	125	6	9	2	1	14.6
125x175	125	175	7	11	2	1	21.8
125x250	125	250	8	13	2	1	33.2
150x150	150	150	5.5	8	2	1	15.8
150x200	150	200	8	12	2	1	28.0
150x300	150	300	10	15	2	1	46.8
175x175	175	175	6	9	2	1	20.6
175x250	175	250	8	12	2	1	34.4
175x350	175	350	10	16	2	1	57.5
200x200	200	200	7	11	2	1	28.2
200x300	200	300	10	16	2	1	53.1
200x400	200	400	13	21	2	1	85.8

Notes : Profiles are Laser fused with full penetration, equivalent to hot rolled  
 $r_1$  = laser welded seam with radius <2 mm  
 Other sizes can be produced upon request with D max. 1000 mm  
 Other stainless steel grades are produced upon request

## HOTO STAINLESS STEEL INDUSTRIES SDN BHD

Lot 3, Solok Sultan Hishamuddin 8,  
Kawasan Perusahaan Selat Kelang Utara,  
42000 Pelabuhan Kelang,  
Selangor, Malaysia.

Tel : +60 3176 1764  
Fax: +60 3176 4735  
www.hoto.com

Company Reg. 285737 -T

# T BARS

**LASER FUSED**, according to ASTM A1069,  
dimensional tolerances and grades, according to  
ASTM A276, ASTM A484, ASTM A479, ASME  
SA479, MTC EN 10204 3.1

Standard stainless steel grades 304/L and 316/L  
Annealed and pickled, lengths of 6000 -0/+100 mm

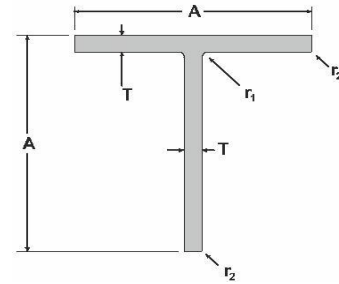

Designation	Dimensions (in mm)			Radius (in mm)		Mass kg/m
	A	A	T	r <sub>1</sub>	r <sub>2</sub>	
20x20x3*	20	20	3	3	2.5	0.89
25x25x3	25	25	3	2	1	1.13
30x30x3	30	30	3	2	1	1.37
30x30x4	30	30	4	2	1	1.79
40x40x3	40	40	3	2	1	1.85
40x40x4	40	40	4	2	1	2.43
40x40x5	40	40	5	2	1	3.00
45x45x4	45	45	4	2	1	2.75
50x50x3	50	50	3	2	1	2.33
50x50x4	50	50	4	2	1	3.07
50x50x5	50	50	5	2	1	3.80
50x50x6	50	50	6	2	1	4.51
60x60x6	60	60	6	2	1	5.47
65x65x6	65	65	6	2	1	5.95
65x65x9	65	65	9	2	1	8.71
70x70x7	70	70	7	2	1	7.45
75x75x6	75	75	6	2	1	6.91
75x75x9	75	75	9	2	1	10.2
80x80x8	80	80	8	2	1	9.73
90x90x9	90	90	9	2	1	12.3
100x100x6	100	100	6	2	1	9.31
100x100x8	100	100	8	2	1	12.3
100x100x9	100	100	9	2	1	13.8
100x100x10	100	100	10	2	1	15.2

\*Hot rolled size

## HOTO STAINLESS STEEL INDUSTRIES SDN BHD

Lot 3, Solok Sultan Hishamuddin 8,  
Kawasan Perusahaan Selat Kelang Utara,  
42000 Pelabuhan Kelang,  
Selangor, Malaysia.

Tel : +60 3176 1764

Fax: +60 3176 4735

[www.hoto.com](http://www.hoto.com)

Company Reg. 285737 -T

# T BARS

**LASER FUSED**, according to ASTM A1069, dimensional tolerances and grades, according to ASTM A276, ASTM A484, ASTM A479, ASME SA479, MTC EN 10204 3.1

Standard stainless steel grades 304/L and 316/L  
Annealed and pickled, lengths of 6000 -0/+100 mm

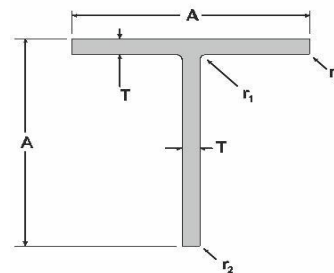

Designation	Dimensions (in mm)			Radius (in mm)		Mass kg/m
	A	A	T	r <sub>1</sub>	r <sub>2</sub>	
120x120x10	120	120	10	2	1	18.4
120x120x13	120	120	13	2	1	23.6
125x125x6	125	125	6	2	1	11.7
125x125x9	125	125	9	2	1	17.4
140x140x10	140	140	10	2	1	21.6
140x140x13	140	140	13	2	1	27.8
150x150x6	150	150	6	2	1	14.1
150x150x9	150	150	9	2	1	21.0

Notes : Profiles are Laser fused with full penetration, equivalent to hot rolled

r<sub>1</sub> = laser welded seam with radius <2 mm

Other sizes can be produced upon request with A max. 1000 mm

Other stainless steel grades are produced upon request

## HOTO STAINLESS STEEL INDUSTRIES SDN BHD

Lot 3, Solok Sultan Hishamuddin 8,  
Kawasan Perusahaan Selat Kelang Utara,  
42000 Pelabuhan Kelang,  
Selangor, Malaysia.

Tel : +60 3176 1764

Fax: +60 3176 4735

[www.hoto.com](http://www.hoto.com)

Company Reg. 285737 -T

# UNIVERSAL BEAMS AND COLUMNS

**LASER FUSED**, according to ASTM A1069, dimensional tolerances and grades, according to ASTM A276, ASTM A484, ASTM A479, ASME SA479, MTC EN 10204 3.1

Standard stainless steel grades 304/L and 316/L  
Annealed and pickled, lengths of 6000 -0/+100 mm

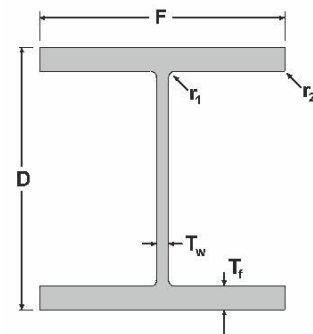

Designation	Dimensions (in mm)				Radius (in mm)		Mass kg/m
	D	F	Tw	Tf	r <sub>1</sub>	r <sub>2</sub>	
100x50	100	50	5	7	2	1	9.0
100x100	100	100	5	7	2	1	14.6
	100	100	6	8	2	1	16.8
125x60	125	60	6	8	2	1	12.9
125x125	125	125	6.5	9	2	1	23.6
150x75	150	75	5	7	2	1	13.8
150x100	148	100	6	9	2	1	20.6
150x150	150	150	7	10	2	1	31.3
	154	151	8	12	2	1	37.3
175x90	175	90	5	8	2	1	17.9
175x125	175	125	5.5	8	2	1	23.0
175x175	171	174	6	9	2	1	32.4
	175	175	7.5	11	2	1	40.0
200x100	198	99	4.5	7	2	1	17.7
	200	100	5.5	8	2	1	20.9
200x150	194	150	6	9	2	1	30.0
	198	151	7	11	2	1	36.4
200x200	196	199	6.5	10	2	1	41.0
	200	200	8	12	2	1	49.7
	204	201	9	14	2	1	57.7
	208	202	10	16	2	1	65.8
250x125	248	124	5	8	2	1	25.2
	250	125	6	9	2	1	29.1
250x175	244	175	7	11	2	1	43.2
	248	176	8	13	2	1	50.8
	252	177	9	15	2	1	58.5

## HOTO STAINLESS STEEL INDUSTRIES SDN BHD

Lot 3, Solok Sultan Hishamuddin 8,  
Kawasan Perusahaan Selat Kelang Utara,  
42000 Pelabuhan Kelang,  
Selangor, Malaysia.

Tel : +60 3176 1764

Fax: +60 3176 4735

[www.hoto.com](http://www.hoto.com)

Company Reg. 285737 -T

# UNIVERSAL BEAMS AND COLUMNS

**LASER FUSED**, according to ASTM A1069, dimensional tolerances and grades, according to ASTM A276, ASTM A484, ASTM A479, ASME SA479, MTC EN 10204 3.1

Standard stainless steel grades 304/L and 316/L  
Annealed and pickled, lengths of 6000 -0/+100 mm

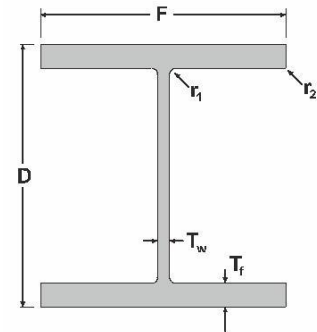

Designation	Dimensions (in mm)				Radius (in mm)		Mass kg/m
	D	F	Tw	Tf	r <sub>1</sub>	r <sub>2</sub>	
250x250	248	249	8	13	2	1	66.0
	250	250	9	14	2	1	72.0
	260	253	12	19	2	1	98.2
300x150	294	148	4.5	6	2	1	24.4
	298	149	5.5	8	2	1	31.5
	300	150	6.5	9	2	1	36.3
	304	150	6.5	11	2	1	41.1
	306	151	7.5	12	2	1	45.9
	318	154	11	18	2	1	69.2
300x200	290	199	7	10	2	1	47.0
	294	200	8	12	2	1	55.7
	298	201	9	14	2	1	64.5
	304	202	10	17	2	1	76.5
300x300	298	299	9	14	2	1	86.4
	300	300	10	15	2	1	93.6
	304	301	11	17	2	1	105.6
	310	303	13	20	2	1	125.0
	310	305	15	20	2	1	130.0
	312	310	20	21	2	1	147.4
350x175	346	174	6	9	2	1	40.8
	350	175	7	11	2	1	49.2
	354	176	8	13	2	1	57.6
	358	177	9	15	2	1	66.1
	360	178	10	16	2	1	71.8
	364	177	11	18	2	1	79.8

## HOTO STAINLESS STEEL INDUSTRIES SDN BHD

Lot 3, Solok Sultan Hishamuddin 8,  
Kawasan Perusahaan Selat Kelang Utara,  
42000 Pelabuhan Kelang,  
Selangor, Malaysia.

Tel : +60 3176 1764

Fax: +60 3176 4735

www.hoto.com

Company Reg. 285737 -T

# UNIVERSAL BEAMS AND COLUMNS

**LASER FUSED**, according to ASTM A1069, dimensional tolerances and grades, according to ASTM A276, ASTM A484, ASTM A479, ASME SA479, MTC EN 10204 3.1

Standard stainless steel grades 304/L and 316/L  
Annealed and pickled, lengths of 6000 -0/+100 mm

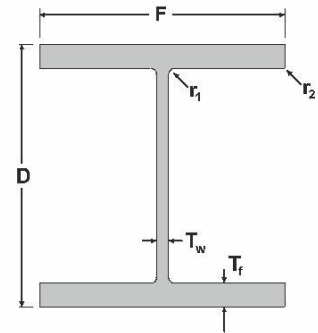

Designation	Dimensions (in mm)				Radius (in mm)		Mass
	D	F	Tw	Tf	r <sub>1</sub>	r <sub>2</sub>	kg/m
350x350	344	348	10	16	2	1	114.0
	350	350	12	19	2	1	136.4
400x200	396	199	7	11	2	1	56.0
	400	200	8	13	2	1	65.5
	404	201	9	15	2	1	75.2
	410	202	10	18	2	1	88.1
400x300	386	299	9	14	2	1	92.8
	390	300	10	16	2	1	105.4
	396	302	12	19	2	1	126.2
400x400	388	402	15	15	2	1	139.4
	394	398	11	18	2	1	146.1
	400	400	13	21	2	1	171.6
450x200	446	199	8	12	2	1	65.2
	450	200	9	14	2	1	75.2
	456	201	10	17	2	1	88.4
	460	202	11	19	2	1	98.5
	460	205	14	19	2	1	109.6
450x300	434	299	10	15	2	1	104.1
	440	300	11	18	2	1	122.0
	446	302	13	21	2	1	143.5
500x200	496	199	9	14	2	1	78.3
	500	200	10	16	2	1	88.6
	506	201	11	19	2	1	102.3
	512	202	12	22	2	1	116.0

## HOTO STAINLESS STEEL INDUSTRIES SDN BHD

Lot 3, Solok Sultan Hishamuddin 8,  
Kawasan Perusahaan Selat Kelang Utara,  
42000 Pelabuhan Kelang,  
Selangor, Malaysia.

Tel : +60 3176 1764

Fax: +60 3176 4735

[www.hoto.com](http://www.hoto.com)

Company Reg. 285737 -T

# UNIVERSAL BEAMS AND COLUMNS

**LASER FUSED**, according to ASTM A1069, dimensional tolerances and grades, according to ASTM A276, ASTM A484, ASTM A479, ASME SA479, MTC EN 10204 3.1

Standard stainless steel grades 304/L and 316/L  
Annealed and pickled, lengths of 6000 -0/+100 mm

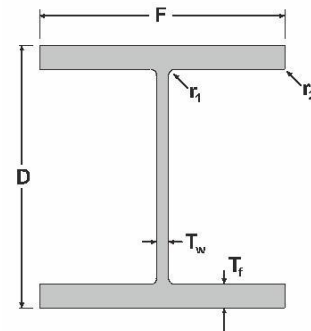

Designation	Dimensions (in mm)				Radius (in mm)		Mass
	D	F	T <sub>w</sub>	T <sub>f</sub>	r <sub>1</sub>	r <sub>2</sub>	kg/m
500x300	482	300	11	15	2	1	111.8
	488	300	11	18	2	1	126.2
	494	302	13	21	2	1	148.5
600x200	592	197	8	13	2	1	77.2
	596	199	10	15	2	1	93.0
	600	200	11	17	2	1	104.2
	606	201	12	20	2	1	118.7
600x300	582	300	12	17	2	1	134.2
	588	300	12	20	2	1	148.6
	594	302	14	23	2	1	172.5
700x300	692	300	13	20	2	1	163.8
	700	300	13	24	2	1	183.0
800x300	792	300	14	22	2	1	189.4
	800	300	14	26	2	1	208.6
900x300	890	299	15	23	2	1	211.3

Notes : Profiles are Laser fused with full penetration, equivalent to hot rolled

r<sub>1</sub> = laser welded seam with radius <2 mm

Other stainless steel grades are produced upon request

## HOTO STAINLESS STEEL INDUSTRIES SDN BHD

Lot 3, Solok Sultan Hishamuddin 8,  
Kawasan Perusahaan Selat Kelang Utara,  
42000 Pelabuhan Kelang,  
Selangor, Malaysia.

Tel : +60 3176 1764

Fax: +60 3176 4735

[www.hoto.com](http://www.hoto.com)

Company Reg. 285737 -T